

PATENT SPECIFICATION

DRAWINGS ATTACHED

L127.915

L127.915



Date of Application and filing Complete Specification: 8 Oct., 1965.

No. 42753/65.

Application made in Czechoslovakia (No. 5802) on 20 Oct., 1964.

Complete Specification Published: 18 Sept., 1968.

© Crown Copyright 1968.

Index at acceptance:—B5 N(17Y, 22X, 60Y, 65Y, 70X, 70Y, 72Y, 79Y, 184, 574, 598, 602, 647, 648, 649, 651, 669, 720, 721, 724, 787, 788, 789, 798); B7 B3

Int. Cl.:—B 32 b 3/06

COMPLETE SPECIFICATION

Improvements in or Relating to Vehicle Bodies

We, KAROSA, NARODNI PODNIK, a Czechoslovakian Body Corporate of Vysoke Myto, Czechoslovakia, do hereby declare the invention, for which we pray that a patent may be granted to us, and the method by which it is to be performed, to be particularly described in and by the following statement:—

This invention relates to a vehicle body, especially a bus body, composed of sandwich panels made of synthetic plastics material foamed between two metal sheets and mutually connected by profiled edge members fastened in the sandwich panels.

In bodies of this kind it is very difficult to join the individual panels together. The connection must be firm and at the same time it must facilitate a quick and economical assembling and an easy disassembling of the panels in case of damage. Welded constructions are very laborious and costly and do not satisfy the mentioned conditions and are not used, riveted and screwed constructions being adopted instead. The screwed constructions give the best fulfilment of all these requirements but with regard to the strain to which the body and the connecting elements, that is, the screws, are exposed, a comparatively great number of them is necessary to fit all the individual panels, resulting in slow assembly and disassembly.

It is an object of this invention to obviate these disadvantages. According to the invention there is provided a vehicle body made up from sandwich panels, each of which is formed from a synthetic plastics material foamed between two metal sheets, and has a profiled edge member provided with male and female members hooked-together with similar complementary members of a profiled edge member of an adjacent panel or of a profiled connecting member interposed between two panels, wherein the profiled edge member is fastened to the panel by the sheets being bent

around the male and female members. The connection made in this way is secured by a small number of screws or rivets. 45

For assembling a whole body two or three fundamental shapes of panel are sufficient, it is not necessary to use any more.

The profiled edge member makes possible a good packing of the panel while foaming synthetic material in the space between the cover sheets. The nature of the panels and of their connection makes it easy to arrange an opening anywhere in the vehicle body and a modification of the profiled edge member that is used to connect the panels can be used for assembling a door. 50 55

An embodiment of the invention will now be described by way of example with reference to the accompanying drawings in which 60

Figure 1 shows the edge portions of two panels,

Figure 2 shows a section through a body wall at the place of connection, 65

Figure 3 is a view of a complete vehicle body, and

Figure 4, 5, 6 and 7 show sections taken on the lines IV—IV, V—V, VI—VI, VII—VII, respectively, of figure 3. 70

As shown in figure 3 a box-type vehicle body is made up from standard panels 10 which form the roof, floor and walls, and from panels 20 which form the doors.

As shown in figures 2 and 1, each panel consists of two sheets, 11 and 12, made from metal, spaced apart by profiled edge members 1 to form a cavity enclosing a foamed plastics material (not shown). 75

The edge members 1 each have a web portion and two flange portions 1a, 1b extending from one side of the web portion and bearing the inner surfaces of the sheets 11, 12 respectively. Projecting from the other side of the web portion are arms 2, 3, the arm 2 forming, in effect a continuation of the flange 80 85

1a and having an inwardly directed projection 2a at its end, and the arm 3 being shorter in length than the arm 2 and turning outwardly at its end to define a channel.

5 The end portion of the sheet 11 is bent inwardly and back parallel to the general plane of the sheet (as best seen in the upper portion of figure 1), such that when the sheets and edge member are assembled, the sheet 11 lies against the outer side of flange 1a and arm 2 and follows the end and inner faces of projection 2a. The sheet 12 is formed with a channel shaped end portion which fits the channel defined by the arm 3 when the sheet is positioned in contact with the flange 1b.

10 The projection 2a and the channel defined by the arm 3 are so shaped and dimensioned, having regard to the thickness of the sheet, that when two panels are brought together in end to end relationship with one panel inverted with respect to the other, as shown in figure 2, the projection 2a of each panel is received within the channel defined by the arm 3 of the other panel.

25 Thus the projection 2a constitutes a male member and the channel — defining arm 3 constitutes a female member, which members are arranged to hook into similar complementary members on a further profiled edge member, or, as will later be described, into similar complementary members on a connecting member.

30 By means of a plurality of panels having edge members identical to that described above, or differing only slightly therefrom, together with connecting members, the box type body of figure 3 can be assembled.

40 The different types of connections between the various panels making up the body are shown in figures 4 to 7.

Figure 4 (which is a sectional view taken on the line IV—IV of figure 3) shows the connection between two panels disposed in the same plane.

45 Figure 5 (which is a sectional view taken on the line V—V of figure 3) shows the connection between two panels lying in mutually perpendicular planes and constituting portions of two walls or of a wall and the roof.

50 The end members 1 of the adjacent panels are identical to those described above and

are connected to a profiled beam 15 having two pairs of projections 2a and channel defining arms 3. The beam 15 has an arcuate part which gives to the edge of the body a rounded, continuous appearance. 55

Figure 6 (which is a sectional view taken on the line VI—VI of figure 3) shows the connection between two panels lying in mutually perpendicular planes and constituting portions of a wall and the floor. 60

The edge members 1 of the adjacent panels are, identical to those described above and are connected to a profiled beam 16 having a pair of projections 2a and a pair of channel-defining arms 3. The beam 16 has an extension of L-shaped cross-section for co-operation, for example, with the chassis of the vehicle. 65

Figure 7 (which is a sectional view taken on the line VII—VII of figure 3) shows the connection between two panels lying in the same plane and constituting the door and a portion of a wall. 70

The end members of adjacent panels are similar to those described above but the arms and projections are modified to ensure correct functioning of the door. In the illustrated example the modification is made by reducing the dimensions of the projections 2a. 75

WHAT WE CLAIM IS:— 80

1. A vehicle body made up from sandwich panels, each of which is formed from synthetic plastics material foamed between two metal sheets and has a profiled edge member provided with male and female members which are hooked into similar complementary members of a profiled edge member of an adjacent panel or of a profiled connecting member interposed between two panels, wherein the profiled edge member is fastened to the panel by the sheets being bent around the male and female members. 85

2. A vehicle body substantially as hereinbefore described with reference to and as illustrated in the accompanying drawings. 90

KAROSA, NARODNI PODNIK,

Per: Boulton, Wade and Tennant,

112, Hatton Garden,

London, E.C.1.

Chartered Patent Agents. 95

Fig. 1.

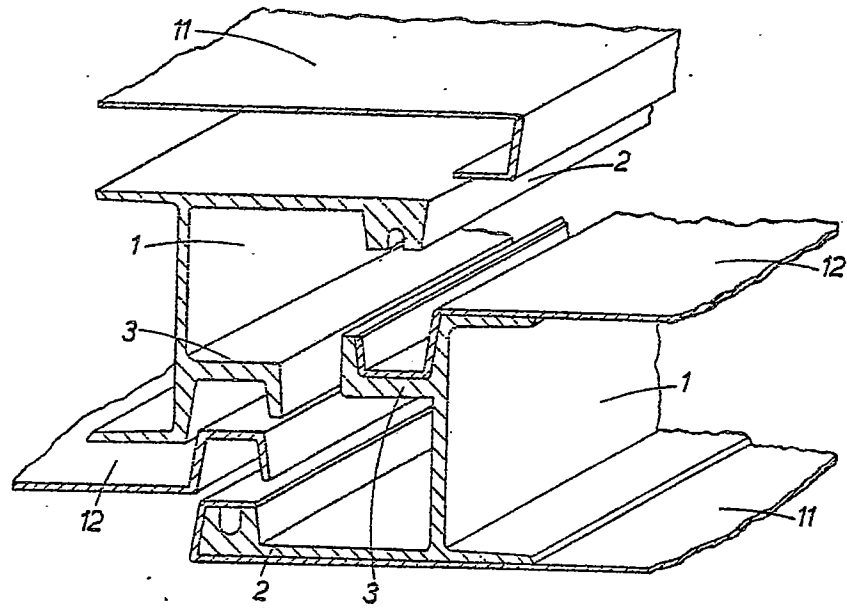

Fig. 2.

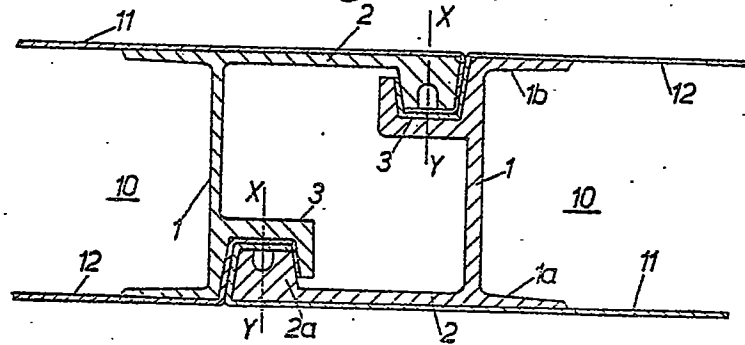

Fig. 5.

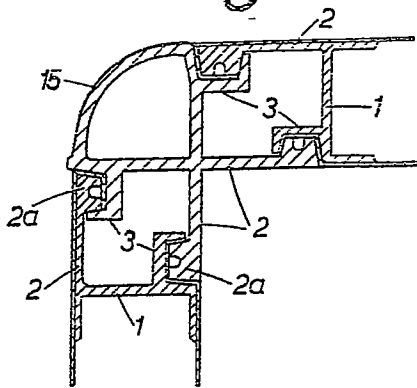

Fig. 4.

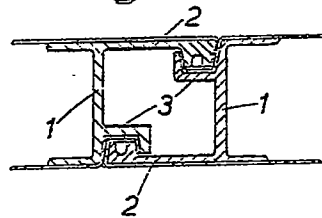

Fig. 3.

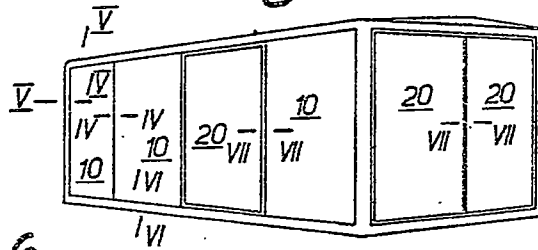

Fig. 6.

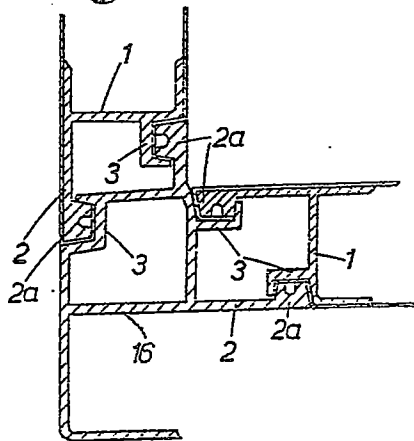
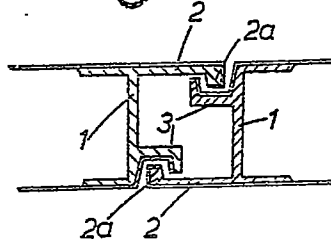

Fig. 7.



Z₁₂

Z₁₁

—

—

1127915 COMPLETE SPECIFICATION
 2 SHEETS This drawing is a reproduction of
 the Original on a reduced scale
 - Sheets 1 & 2

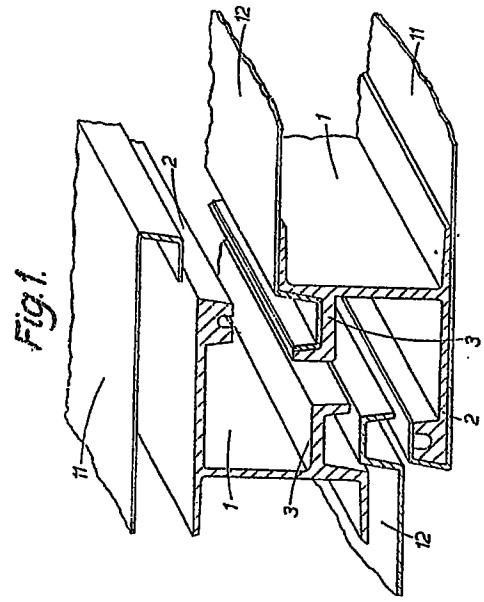

Fig. 1.

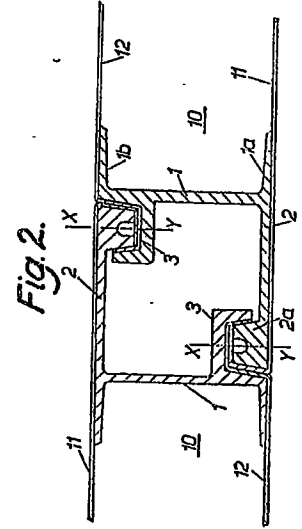

Fig. 2.

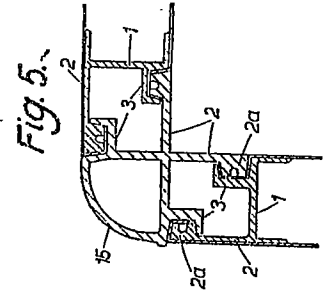

Fig. 5.

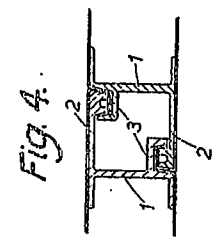

Fig. 4.

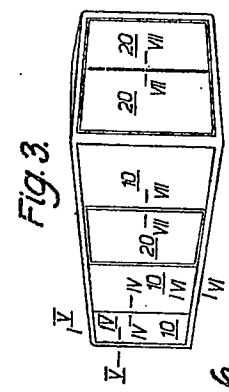

Fig. 3.

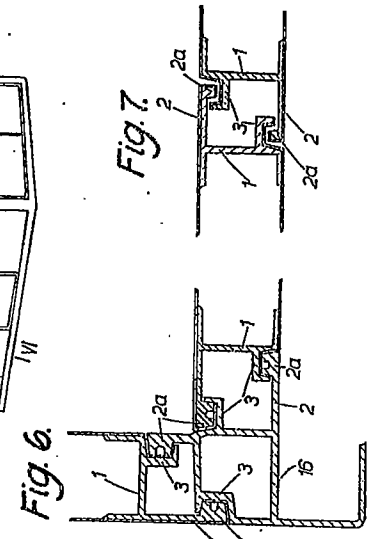

Fig. 6.

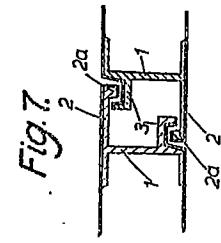

Fig. 7.